

4992TRM Tub/Shower Trim Specification Submittal

Location:

Model Numbers

- 4992TRM**
Tub/Shower Trim

Valve Options:

- 262 Series Temptrol® Shower Valve with TRM modifier
- 162 Series Temptrol Shower Valve requires TC modifier

Feature Highlights

- Verity Tub/Shower Trim.
- Requires Temptrol Pressure-Balancing Shower Valve.
- Metal lever handle.
- Slip-on diverter tub spout.
- Single-mode showerhead.
- Standard flow rate, 2.0 gpm (7.6 L/min).
- Components shall be metal and nonmetal construction, plated in standard Polished Chrome finish.

Compliance

- ASME® A112.18.1/CSA® B125.1
- WaterSense® 1.5 gpm (5.7 L/min) 2.0 gpm (7.6 L/min)
- Lever handle meets ADA requirements for operation
- 1.5 gpm option meets CALGreen requirements



Options/Modifications

- 15**  1.5 gpm (5.7 L/min) flow restrictor
- L1** Less showerhead
- L4** Less showerhead, arm, and flange
- L7** Less handle
- TC** Test Cap Trim (includes TA-10™ & T-12A) *used with 162 Series Temptrol Shower Valve*
- MB** Matte Black finish
- STN** Satin Nickel finish

Warranty

Limited Lifetime - for residential installations.

10 Years - for commercial/industrial installations.

Refer to www.symmons.com/warranty for complete warranty information.

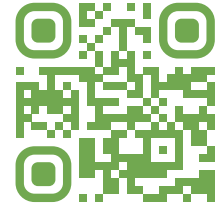

SKU Builder

Series	Finish	Modifier	Flow Rate	Trim (required)	Test Cap	Final SKU
4992	STN	L7	15	TRM		4992STNL715TRM
4992	MB			TRM	TC	4992MBTRMTC

Notes: No more than two modifiers (L1-L7) permitted when ordering. Modifiers will list in numerical order.

Architectural/Engineering Specification

Symmons _____ Includes Verity Tub/Shower Trim for Temptrol® Pressure-Balancing Shower Valve. Features metal lever handle, slip-on diverter tub spout, single-mode showerhead, and standard 2.0 gpm (7.6 L/min) flow rate. Components shall be metal and nonmetal construction, plated in standard Polished Chrome finish. 10-Year Commercial Warranty. ASME A112.18.1/CSA B125.1, WaterSense 1.5 gpm (5.7 L/min) and 2.0 gpm (7.6 L/min) compliant. Lever handle meets ADA requirements for operation. 1.5 gpm option meets CALGreen requirements. Available options: 15 = 1.5 gpm (5.7 L/min) flow restrictor, L1 = Less showerhead, L4 = Less showerhead, arm, and flange, L7 = Less handle, TC = Test Cap Trim, MB = Matte Black finish, STN = Satin Nickel finish.

Dimensions

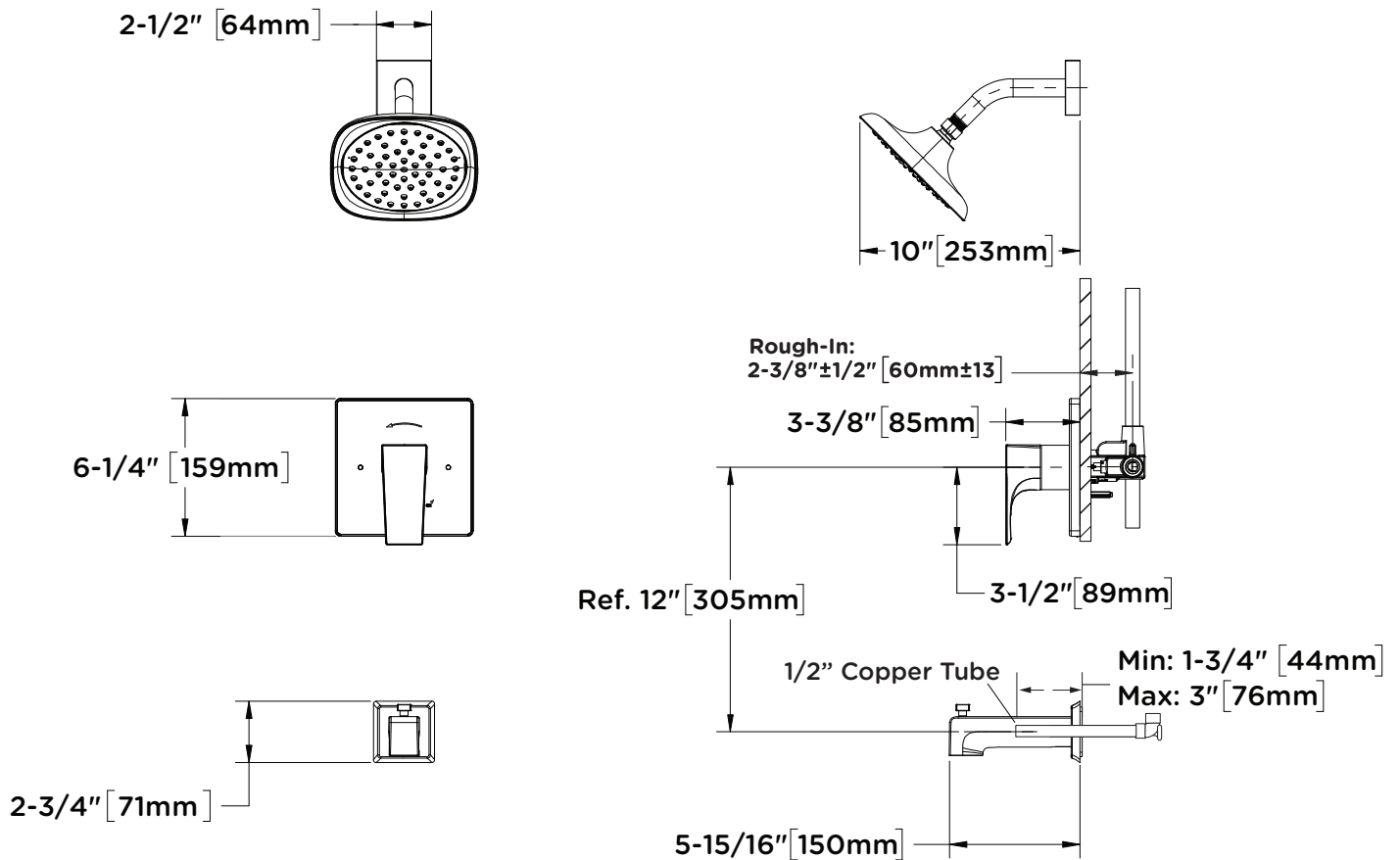

Notes:

- 1) Valve body and piping not included and shown as reference only.
- 2) Plaster shield (p/n T-176) for drywall, plaster, or other type walls 1/2" or greater.
- 3) All dimensions measured from nominal rough-in.
- 4) Dimensions subject to change without notice.