

TIP TAP DRAIN ASSEMBLY
MODEL: P-02827
INSTALLATION GUIDE

FEATURE HIGHLIGHTS

Tip Tap Drain Assembly shall feature tip-tap drain mechanism to easily open and close drain stopper.
 Tip Tap Drain Assembly shall be metal construction plated in standard polished chrome finish.

FINISH OPTIONS/MODIFICATIONS

- STN** Satin Nickel finish
- BBZ** Brushed Bronze finish

Note: Append appropriate -suffix to model number.

COMPLIANCE

- ASME A112.18.1/CSA B125.1



WARRANTY

5 Years - for industrial/commercial installations.
 Refer to symmons.com/warranty for complete warranty information.

DIMENSIONS

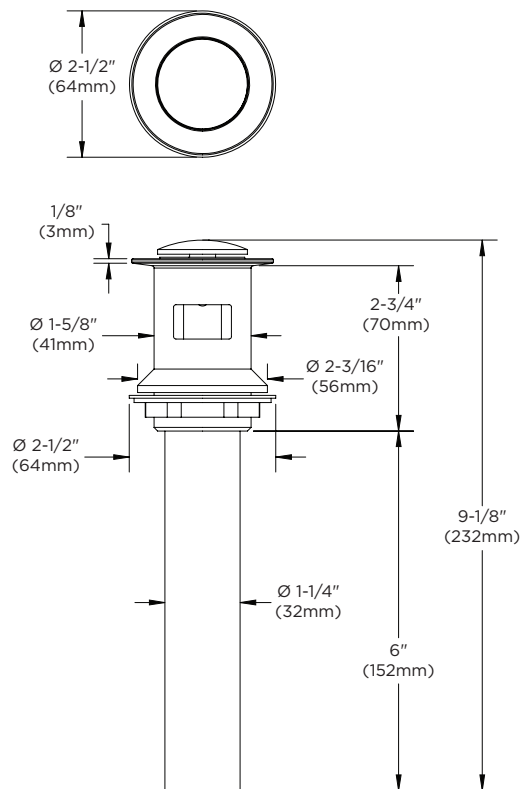

Note: Dimensions subject to change without notice.