



**S6430B/E SENSOR FAUCET**  
ELECTRONIC LAVATORY FAUCET

**INSTALLATION AND MAINTENANCE GUIDE**

# INDEX

- 1 TECHNICAL DATA
- 2 PACK CONTENTS
- 3 PRE-INSTALLATION INFO
- 4-6 INSTALLATION
- 7 BATTERY REPLACEMENT
- 8-9 SETTINGS ADJUSTMENT
- 10 SPARE PARTS LIST
- 10 MAINTENANCE
- 11 LIMITED WARRANTY
- 12 TROUBLESHOOTING

The information in this document reflects products at the date of printing. The manufacturer reserves the right, subject to all applicable laws, at any time, at its sole discretion, and without notice, to discontinue or change the features, designs, materials and other specifications of its products, and to either permanently or temporarily withdraw any of the foregoing from the market. All information in this document is provided "as is" without warranty of any kind, either expressed or implied, including but not limited to any implied warranties of merchantability, fitness for a particular purpose, or non-infringement. The manufacturer assumes no responsibility for errors or omissions in the information presented in this document. In no event shall the manufacturer be liable for any special, incidental, indirect or consequential damages of any kind, or any damages whatsoever arising out of or in connection with the use or performance of this information. The tradenames, trademarks, logos and service marks presented in this document, including their design, are the property of the manufacturer or other third parties and you are not permitted to use them without the prior written consent of the manufacturer or such third party as may own them.

# TECHNICAL DATA

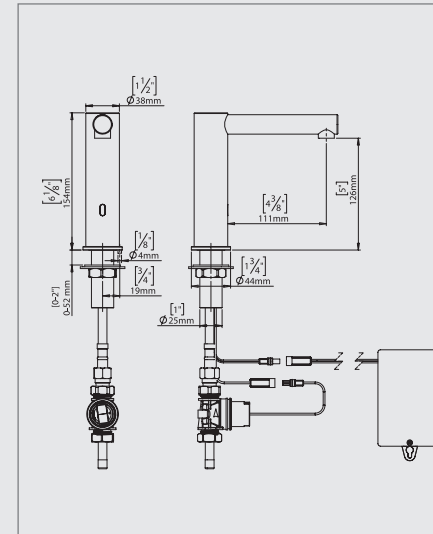

**BATTERY POWERED**

**S6430B**

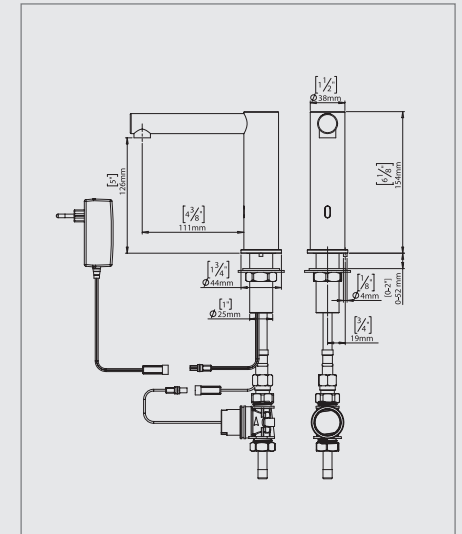

**ELECTRIC POWERED**

**S6430E**

<b>Power supply</b>	6X1.5V AA batteries or 9V transformer
<b>Recommended water pressure</b>	0.5-8.0 bar (7-116 PSI) With water pressure of more than 8 bars, use a pressure reducing valve for reduction.
<b>Preset sensor range</b>	220mm / 8.66" (customizable with optional remote control)
<b>Minimum sensor range</b>	80 mm / 3.15"
<b>Maximum sensor range</b>	300 mm / 11.81"
<b>Security time</b>	90 seconds (can be reduced with optional remote control)
<b>Hot water temperature</b>	Max 70°C

## PACK CONTENTS

Familiarize yourself with the part names and confirm that the parts are included.

### 1 X FAUCET AND ATTACHMENTS

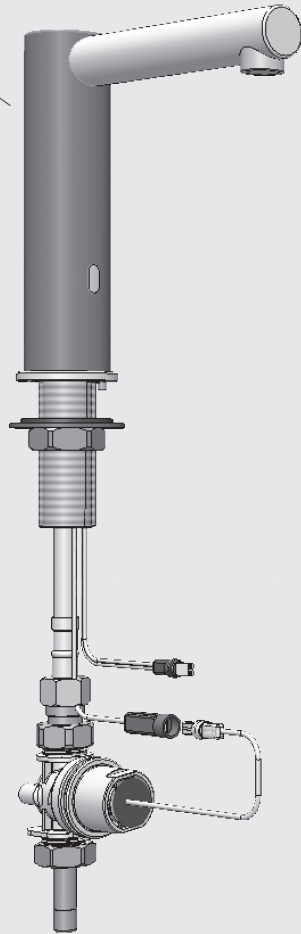

1 X FILTER



1 X ALLEN KEY

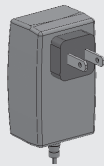

9V SWITCHING  
TRANSFORMER FOR  
S6430E



BATTERY VERSION  
BATTERY BOX FOR  
6 X 1.5V AA BATTERIES

## PRE-INSTALLATION INFO

### CHECK CONTENTS

Separate all parts from the packaging and check each part with the “Pack contents” section.

Pay attention to the different models variations.

Make sure all parts are accounted for before discarding any packaging material.

If any parts are missing, do not attempt to install your electronic faucet until you obtain the missing parts.

### WARNINGS

Do not install facing a mirror or any other electronic system operated by an infrared sensor.

To prevent reflection problems, it is recommended to keep a minimum distance of 1.50 meters between the faucet and any other objects.

### PREPARATION FOR INSTALLATION

Flush water supply lines thoroughly before installing the faucet. Do not allow dirt, Teflon tape or metal particles to enter the faucet.

Shut off water supply.

**IMPORTANT:** All plumbing is to be installed in accordance with applicable codes and regulations.

### RECOMMENDED HOLE SIZE

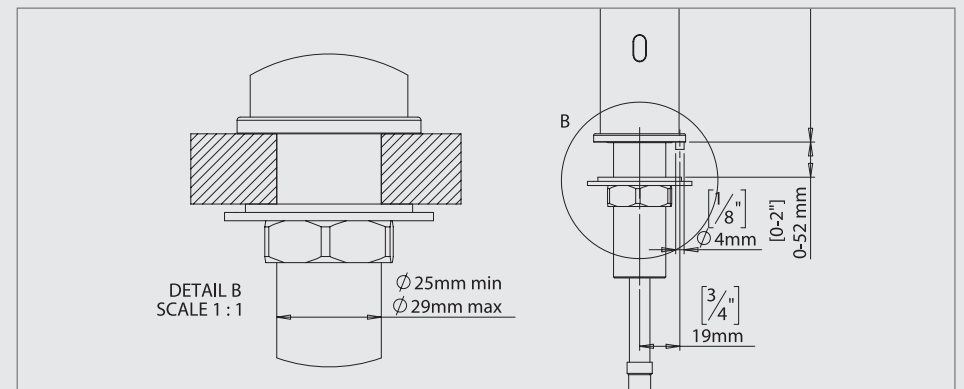

# INSTALLATION

## STEP 1 – PREPARATION FOR MOUNTING THE FAUCET

1 Shut off the water supply.



2 Remove the hexagonal nut, the disk and the gasket. Do not remove the O-ring from the base of the faucet.

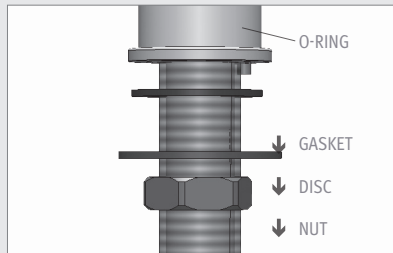

## STEP 2 – INSTALLING THE FAUCET

1 Place the faucet with O-ring into the hole in deck or lavatory. Make sure the O-ring is located between the deck or lavatory and the bottom of the faucet.

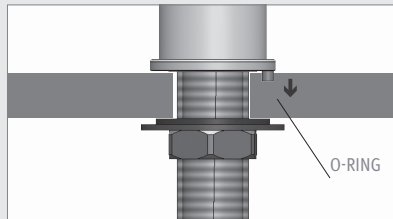

2 Slide the gasket, disk and hexagonal nut over the flexible hose and secure the faucet into place.

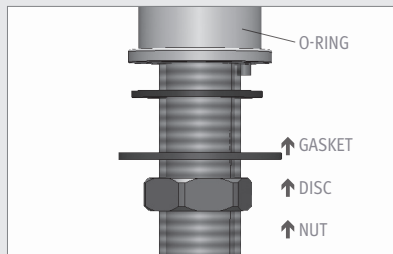

# INSTALLATION

## STEP 3 – CONNECTING THE WATER SUPPLY

1 Connect the flexible pipe to the water supply.  
*For models with temperature control connect the red flexible pipe to the hot water supply and the blue flexible pipe to the cold water supply.*

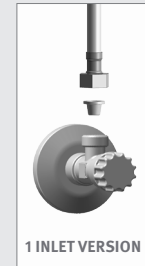

**MAKE SURE THAT THE FILTER(S) IS/ARE INSTALLED BETWEEN THE FLEXIBLE PIPE AND THE SHUT OFF VALVE (ANGLE VALVE) (NOT SUPPLIED).**

2 Turn on the central water supply and the shut-off valves (angle valves) and check for leaks.



# INSTALLATION

## STEP 4 – CONNECTING THE POWER SOURCE

### BATTERY VERSION

Install the batteries in the battery box and attach the box to the wall underneath the sink.

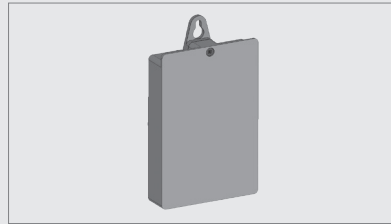

1

### TRANSFORMER VERSION

Plug the transformer into the electricity socket and connect the connectors.

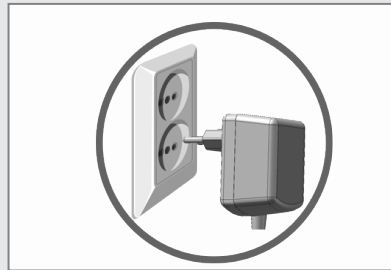

2

In order to avoid entering into the adjusting mode, wait 10 seconds before operating the faucet. If the range is unsatisfactory, refer to the section titled “settings adjustment.”



ABOUT  
**10**  
SECONDS

NOTE: This model includes a special aerator that allows you to adjust the water stream direction on site in order to prevent water splashing if needed. To change the angle of the water stream, simply move the adjustable tilting plate by pressing it smoothly.



**ATTENTION!** the aerator is tightened to prevent removal by hand.

# BATTERY REPLACEMENT

When the battery weakens, the LED indicator light will blink at a constant rate. The battery must be replaced within two weeks.

<p>1. Unscrew the holding screw</p>	<p>2. Carefully open the battery box</p>	<p>3. Remove the old batteries</p>
<p>4. Replace the used batteries with a new 6 X 1.5V batteries (Lithium battery is recommended).</p>	<p>5. Close the box</p>	

**IMPORTANT:** Spent batteries should not be disposed of with normal household waste. Contact your local authority for information on waste disposal and recycling.



## SETTINGS ADJUSTMENT



### Adjusting the settings with the remote control

If necessary, the sensor settings can be adjusted as following:

Shut off the water supply. In order to adjust the sensor with the remote control, hold the remote control straight in front of the sensor in a distance of about 6-8" (15-20cm). Choose the function you want to adjust by pressing once on one of the function buttons. After pressing once on a specific function button, a quick flashing of the LED at the front of the sensor will occur. At this stage, you can change the setting by pressing the (+) or the (-) buttons, every push will increase or decrease one level. After finishing the adjustment, turn the water supply back on.



**DETECTION RANGE:** Only if necessary, use the remote control to adjust the sensor range as follows:

Press the RANGE button. Wait until a quick flashing of the LED in the sensor eye is perceived. Then, press + to increase the one level and – to reduce it every push will increase or decrease one level.

**NOTE:** Once you have changed the detection range with the remote control, this distance will be remembered by the sensor, even if the power source is disconnected.

## SETTINGS ADJUSTMENT



**DELAY IN TIME:** If required, the delay in time can also be modified as follows: Press the IN button. Wait until a quick flashing of the LED in the sensor eye is perceived. Then, press + to increase the delay in time and – to reduce it.



**DELAY OUT TIME:** This button allows modifying the flushing start time after the user moves away from the product. A delay out time close to 0 will save more water. An increased delay out time will make the user experience more comfortable.

If required, the delay out time can be modified as follows: Press the OUT button. Wait until a quick flashing of the LED in the sensor eye is perceived. Then, press + to increase the delay out time and – to reduce it.



**TEMPORARY OFF FUNCTION:** This function is ideal to perform any kind of activity in front of the sensor without operating the system (for example, cleaning).

The product will remain shut for 1 minute when this button is pressed once. To cancel this function and to return to normal operation press the On/Off button again or wait 1 minute.



**RESET BUTTON:** This function restores all the factory settings except for the sensor range. If required, press the Reset button and without releasing it, press the + button once.



**SECURITY TIME:** The Security time, prevents continuous flushing of water due to reflections or vandalism. By default, if the sensor is covered for more than 90 seconds the water flow will shut automatically. To resume regular operation any obstruction must be removed.

Press the SEC button. Wait until a quick flashing of the LED of the sensor eye is perceived. Then, press + to increase the security time and – to reduce it.



**24 HOUR HYGIENE FLUSH:** This model includes a 24 hours hygiene flush which is disabled. To activate the hygiene flush, press the clock button. Wait until a quick flashing of the LED in the sensor eye is perceived. Then press + to activate the hygiene flush. To disable it again, press – to deactivate it.



**COMFORT FLUSH:** If your model includes a COMFORT FLUSH setting, it can be activated by pressing the flush button.

When the button is pressed, one blink of the blue in the sensor eye is perceived. The pre-programmed flush cycle will take place then.

The Comfort flush cannot be interrupted or deactivated by pressing any button until it is over.

## SPARE PARTS LIST

SEALS AND SCREWS KIT	SF250
10-PACK SENSOR KIT	SF252
10-PACK SOLENOID VALVE KIT	SF254
8-PACK SOLENOID HOUSING KIT	SF256
INSERT KIT	SF257
BATTERY BOX FOR 6X1.5V AA BATTERIES	SF258
9V SWITCHING TRANSFORMER (US PLUG)	SF259
REMOTE CONTROL 13B (OPTIONAL)	SF260

## MAINTENANCE

### FILTER CLEANING INSTRUCTIONS

This faucet is provided with one / two stainless steel filter(s) preventing foreign particles to enter the lines. If the water flow has decreased, this can be because the filter(s) is/are clogged. The filter(s) can be cleaned as follows:

1. Shut-off the water shut off valve (angle valve).
2. Disconnect the flexible pipe/s.
3. Remove the filter(s) and wash it/them under running water.
4. Reassemble the parts.
5. Make sure that there is no water leakage.

### SOLENOID VALVE SERVICING

The solenoid valve diaphragm requires periodical cleaning every six (6) month. Remove the diaphragm from the solenoid valve and examine it for dirt. In case it is dirty or clogged, wash it under running water and reassemble it. Do not attempt to dismantle the solenoid valve if you are unfamiliar with electronic solenoid valves.

### CARE AND CLEANING OF CHROME AND SPECIAL FINISHES

**DO NOT** use steel wool or cleansing agents containing alcohol, acid, abrasives, or the like. Use of any prohibited cleaning or maintenance products or substances could damage the surface of the faucet. For surface cleaning of faucet use **ONLY** soap and water, then wipe dry with clean cloth or towel. When cleaning bathroom tile, the faucets should be protected from any splattering of harsh cleansers.

## LIMITED WARRANTY

The manufacturer warrants that its electronic products will be free of defects in material and workmanship during normal use for two years from the date the product is purchased.

If a defect is found in normal use, the manufacturer will, at its discretion, repair, provide a replacement part or product, or make appropriate adjustments. Damage caused by accident, misuse, or abuse is not covered by this warranty. Improper care and cleaning will void the warranty. Proof of purchase (original sales receipt) must be provided to the manufacturer with all warranty claims.

The manufacturer is not responsible for labor charges, installation, or other incidental or consequential costs other than those noted above. In no event shall the liability of the manufacturer exceed the purchase price of the product.

If you believe that you have a warranty claim, contact your Distributor, Dealer or Plumbing Contractor. Please be sure to provide all pertinent information regarding your claim, including a complete description of the problem, the product, model number, the date the product was purchased, from whom the product was purchased and the installation date. Also include your original invoice.

THE MANUFACTURER AND/OR SELLER DISCLAIM ANY LIABILITY FOR SPECIAL, INCIDENTAL OR CONSEQUENTIAL DAMAGES. This warranty excludes product damage due to installation error, incorrect maintenance, wear and tear, battery, product abuse, or product misuse, whether performed by a contractor, service company, or the consumer. This warranty does not cover product damage caused by the following:

- Incorrect installation.
- Inversions of supply pipes.
- Pressures or temperatures exceeding recommended limits.
- Improper manipulation, tampering, bad or lapsed maintenance.
- Foreign bodies, dirt or scale introduced by the water supply or soap tank.
- Use of the soap outside of viscosity specifications.
- Alteration of the original soap/foam dispenser components (including pipes).

# TROUBLESHOOTING

PROBLEM	INDICATOR	CAUSE	SOLUTION
No water coming out of the faucet:	1. Sensor flashes continuously when user's hands are within the sensor's range.	Low battery.	Replace battery
	2. LED in the sensor does not flash once when user's hands are within the sensor's range.	1. Range is too short.	Increase the range
		2. Range is too long.	Decrease the range
		3. Battery is completely used up	The battery must be replaced.
		4. Unit is in "Security Mode"*	
	3. LED in the sensor flashes once when user's hands are within the sensor's range.	5. Sensor is picking up reflections from the washbasin or another object.	Eliminate cause of reflection.
1. Connectors between the electronic unit and solenoid are disconnected.		Connect the electronic unit connectors to the solenoid.	
		2. Debris or scale in solenoid.	Unscrew solenoid, pull out the plunger and the spring from the solenoid and clean them. Use scale remover material if needed. When replacing the plunger, please make sure that the spring is in vertical position.
3. The central orifice in the diaphragm is plugged or the diaphragm is torn		Clean the orifice or replace diaphragm.	
4. The water supply pressure is higher than 8 bar.		Reduce the supply water pressure.	
5. The water supply pressure is under 8 bars and yet the pressure in the faucet's body is higher. This situation could be caused by a sudden increase in the water supply pressure that the back check prevents from dropping, even after water supply pressure drops under 8 bars.	Shut off water supply and unscrew one of the flexible pipes in order to reduce the pressure that blocks the product.		
Water flow from spout does not stop:	1. Sensor flashes once when user's hands are within the sensor's range.	1. Debris or scale in diaphragm	Clean the orifice or replace diaphragm.
	2. LED in the sensor does not flash once when user's hands are within the sensor's range.	1. Sensor is dirty or covered.**	Clean or eliminate cause of interference.
		2. Sensor is picking up reflections from the washbasin or another object.	Decrease the range or eliminate cause of reflection.
Water flow diminished		Filter or aerator is clogged	Remove, clean, re-install

\* "Security Mode": If the sensor is covered for more than 90 sec. the faucet will automatically shut off water flow.

To return to normal operation remove any blockage.

\*\* In this case, the water flow will stop anyway after 90 seconds because of the security time.





---

Symmons Industries, Inc.  
31 Brooks Drive  
Braintree, MA 02184-3804  
1-800-796-6667